



ISSF Workshop 2012

**Organization of activities on international competitions
in 2012.**

**New rules of the ISSF which are going to be applied in
2013.**

Keys to improved competitions

**Tomislav Šepec
ISSF Rifle Committee Chairman**

Introduction

- **We are ending 2012, the year in which we have more than successfully organized great shooting competition and above all excellently organized Olympic Games in London 2012.**
- **I must admit that I am more than proud of the successful results, achieved records, technical conditions on all international competitions and of the constant cooperation in realization those common activities.**

I would especially like to emphasize extraordinary and continuous activity of the ISSF, authorities and Committees on the construction of the new rules which will be applied from 2013 and achieved union in solving individual demanding changes which are surely going to provide further extraordinary status in our shooting sport in great Olympic family.



I would like to thank Vice-President Gary Anderson, Secretary General Franz Schreiber and members of the ADHOC Committee on their effort to develop New rules.

Why we are on that level

- **- Jobs and tasks of the organizer of great competitions**
- **- Project design of the entire organization of the competition**
- **- Absolute respect for all ISSF Rules and Regulations**
- **- Preparation of facilities and all other contents on time in accordance with rules.**

- - **Training of skilled, technical and other staff who will conduct competition.**



- - **Cooperation with Technical Delegate and Jury members is extremely important for the successful organization of the competition.**

I would like to highlight some of the problems that we encountered in the organization of the competition in 2012 and at the same time I'd like to thank Willi Grill and all the other Jury members who pointed out some problems and their successful resolution on great international competitions from World Cups to Olympic Games :



- - **Issue of the well-timed preparation of all technical details associated with**

- **implementing**

- **competition :**

-control of possible shadows on the targets



- flag height for wind

- the level of the shooting places



- area for storage of arms and equipment in warehouses and on a shooting line



- procedure of equipment control and constant control of the instruments for tests



- procedures of ADHOC control and organization of area for the implementation of this.

- **area for Jury members and staff close to shooting facilities**

- **examination of technical correctness of Shooting Range in all elements**

- **organization of transport between the hotel accomodation and shooting facilities with a sufficient number of buses and at appropriate time schedule and schedule of events.**



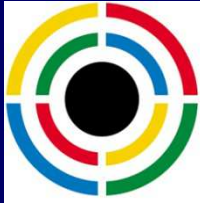

ISSF

**10TH
ISSF CHAMPIONSHIP ORGANIZERS WORKSHOP
MUNICH, GER**

23 NOV - 24 NOV 2012



Changes in the 2013 Rifle Rules

Malfunction Rules

Keys to improved Competitions

Range Officer & Jury Member Manuals

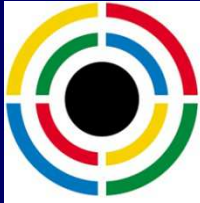

ISSF

**10TH
ISSF CHAMPIONSHIP ORGANIZERS WORKSHOP
MUNICH, GER**

23 NOV - 24 NOV 2012

One Rifle Per Event.

**Only one (1) rifle is allowed to be used in the
competition or Finals**



**10TH
ISSF CHAMPIONSHIP ORGANIZERS WORKSHOP
MUNICH, GER
23 NOV - 24 NOV 2012**

Movement or Oscillation Reduction Systems.

**Any device,
mechanism or system that actively reduces, slows or
minimizes
rifle oscillations or movements before the shot is released
is
prohibited.**

**Is is an illegal active system to stabilise the barrel before
the shot is fired, and for that we have to protect our
athletes.**



**10TH
ISSF CHAMPIONSHIP ORGANIZERS WORKSHOP
MUNICH, GER
23 NOV - 24 NOV 2012**

Electronic triggers

All components are firmly attached to and contained within the action or stock of the rifle so that the battery and wires are not **visible externally;**



**10TH
ISSF CHAMPIONSHIP ORGANIZERS WORKSHOP
MUNICH, GER
23 NOV - 24 NOV 2012**

The pistol grip extensions is 60mm

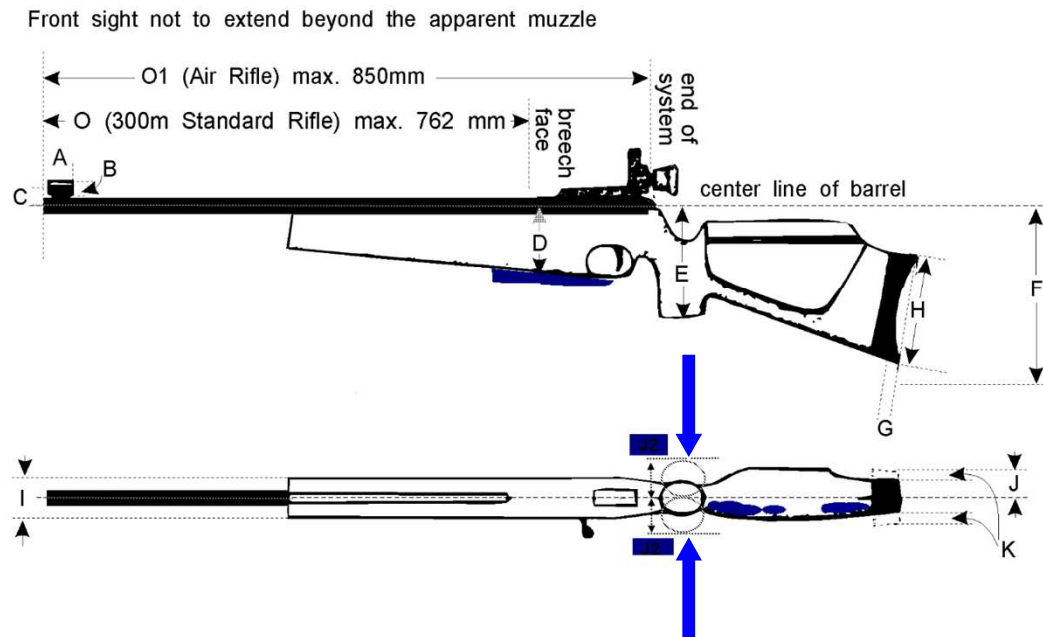



**10TH
ISSF CHAMPIONSHIP ORGANIZERS WORKSHOP
MUNICH, GER
ISSF 23 NOV - 24 NOV 2012**

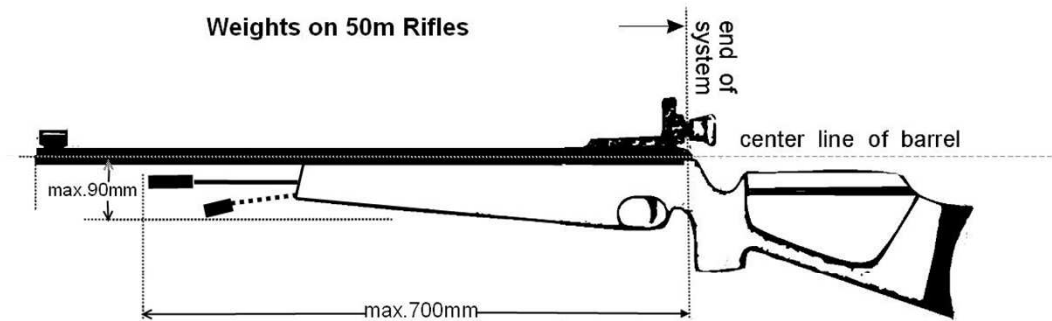

Weights on the fore-end of the rifle may extend no lower than 90mm below the center line of the barrel and not further forward than 700mm from the back(rear) end of the system



Butt Plate and Hook

not extend more than 25 mm to the rear of this perpendicular line; and Any devices or weights projecting forward from the lower portion of the butt plate are prohibited.

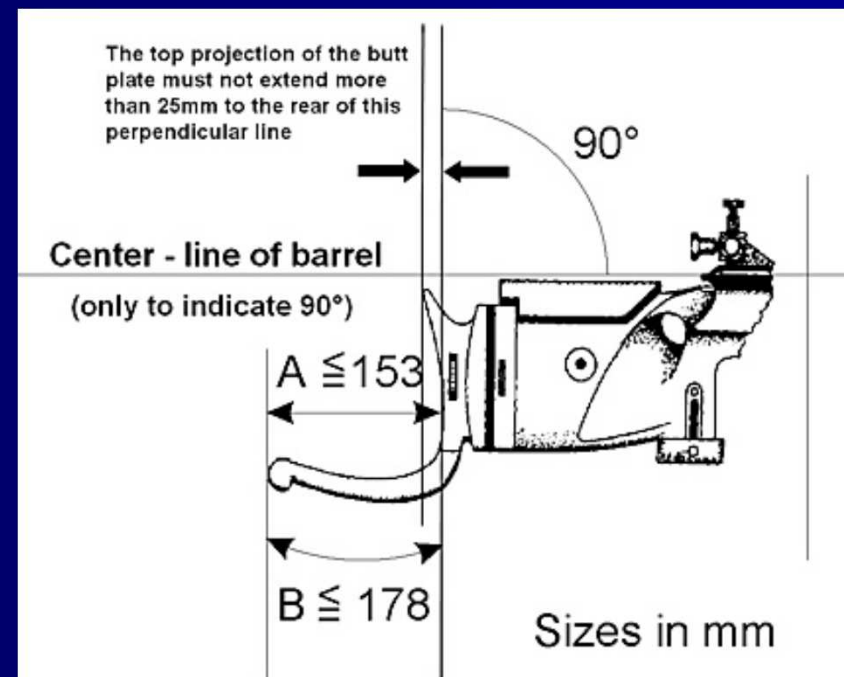



**10TH
ISSF CHAMPIONSHIP ORGANIZERS WORKSHOP
MUNICH, GER
23 NOV - 24 NOV 2012**

Shooting Shoes

No special shooting shoes are allowed in the 50m prone event.

The shoe sole must follow the external curvature of the shoe and may not extend more than 5.0 mm beyond the external dimensions of the shoe at any point. Toes or heels may not be cut square or flat.

If a shoe has a square toe for example the sole must be round

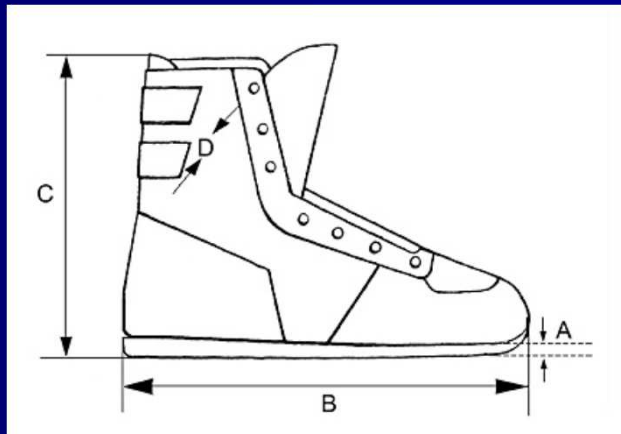



**10TH
ISSF CHAMPIONSHIP ORGANIZERS WORKSHOP
MUNICH, GER
ISSF 23 NOV – 24 NOV 2012**

Shooting Jacket

The construction of the side panel may not place any horizontal seam or seams **under the elbow of the support arm** in the standing position.

The athlete must be capable of **fully extending both arms** (straighten sleeves) while wearing the buttoned jacket.

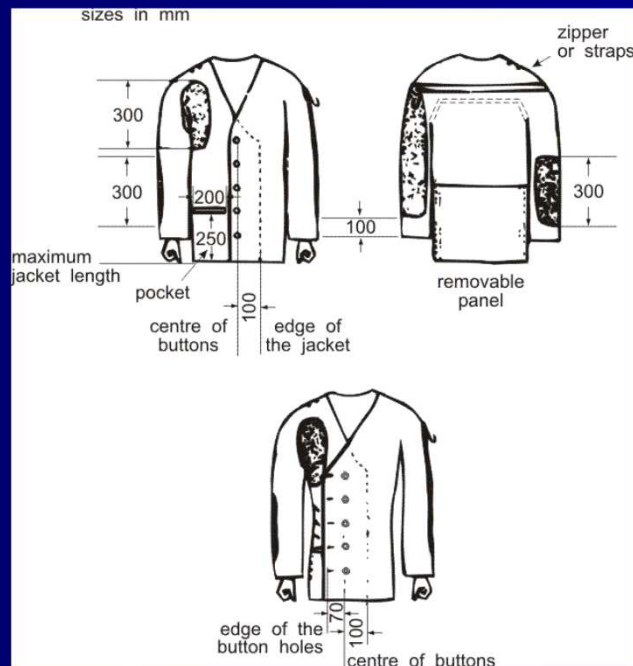



**10TH
ISSF CHAMPIONSHIP ORGANIZERS WORKSHOP
MUNICH, GER
23 NOV – 24 NOV 2012**

Shooting Trousers

No seat pad on trousers

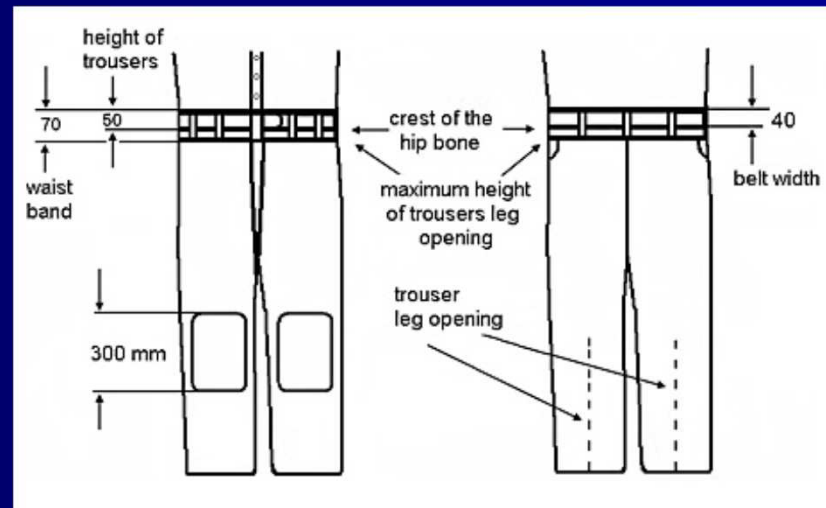



**10TH
ISSF CHAMPIONSHIP ORGANIZERS WORKSHOP
MUNICH, GER
23 NOV - 24 NOV 2012**

Rifle Rests

The use of a rifle rest for resting the rifle between shots is permitted providing that it is not no part of the stand is higher than the athlete's shoulders when in the standing position.

A stand for resting the rifle must not be placed in front of the shooting table or bench in the standing position.

A kneeling roll may be used as a rifle rest.



**10TH
ISSF CHAMPIONSHIP ORGANIZERS WORKSHOP
MUNICH, GER
23 NOV - 24 NOV 2012**

Kneeling Heel Pad

A separate piece of flexible, compressible material with maximum dimensions of 20 cm x 20 cm may be placed on the heel in the kneeling position. The kneeling heel pad may be no thicker than 10mm when compressed measured with the thickness device .

Visor or Cap

A cap or visor may be worn, but it must not touch or rest on the rear sight while the athlete is shooting. The cap or visor may extend forward of the athlete's forehead no more than 80 mm and may not be worn in a way that makes it a side blinder.

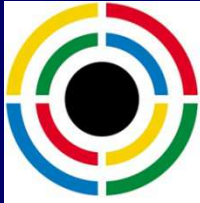

ISSF

**10TH
ISSF CHAMPIONSHIP ORGANIZERS WORKSHOP
MUNICH, GER**

23 NOV – 24 NOV 2012

RIFLE EVENTS

50 m and 300 m three position events must be fired in order:
Kneeling -- Prone – Standing.

A combined 15-minute Preparation and Sighting period must be provided before MATCH firing starts

No change over time anymore , is one total time .



**10TH
ISSF CHAMPIONSHIP ORGANIZERS WORKSHOP
MUNICH, GER
ISSF 23 NOV – 24 NOV 2012**

ISSF Rule 7.9

Event	Men/ Women	No. of Shots	Number of Shots Per MATCH Target (paper)	Number of Sighting Targets(paper)	Time: Pit Operated or Target Carriers (when paper targets are used)	Time: Electronic Targets
10m Air Rifle	Men Women	60 40	1	4	1 hour, 15 minutes 50 minutes	1 hour, 15 minutes 50 minutes
50m Rifle 3 Positions	Men	120	1	4 for each position	3 hours, 15 minutes	2 hours, 45 minutes
50m Rifle 3 Positions	Women	60	1	4 for each position	2 hour	1 hour, 45 minutes
50m Rifle Prone	Men Women	60 60	1	4	1 hour	50 minutes
300m Rifle 3 Positions	Men	120	10	1 for each position	3 hours, 30 minutes	3 hours
300m Rifle 3 Positions	Women	60	10	1 for each position	2 hours, 15 minutes	2 hours,
300m Rifle Prone	Men Women	60 60	10	1	1 hour, 15 minutes	1 hour,
300m Standard Rifle 3 Positions	Men	60	10	1 for each position	2 hours, 15 minutes	2 hours,

Note: The combined Preparation and Sighting Period of 15 minutes starts before the published start time of the event.



**10TH
ISSF CHAMPIONSHIP ORGANIZERS WORKSHOP
MUNICH, GER
23 NOV - 24 NOV 2012**

Safety flags must be inserted in all rifles, pistols and semiautomatic shotguns at all times other than during authorized dry firing or live firing on a firing point. The purpose of safety flags is to visibly demonstrate when gun actions are open and guns are unloaded.





**10TH
ISSF CHAMPIONSHIP ORGANIZERS WORKSHOP
MUNICH, GER
23 NOV - 24 NOV 2012**

General and Administrative Facilities

One Main Scoreboard for posting official results and notices, and smaller Range Scoreboards on each range for posting preliminary results; a scoreboard should also be placed in the athletes rest area;

6.4.3.5 Each range must be equipped with a large clock at each end of the hall on which the time can clearly be seen by athletes and officials. The Finals range preparation area must also have a clock. Range clocks must be synchronized with results computers to show the same time. Rifle and Pistol Finals ranges must have a count-down clock that shows the time remaining for each shot.

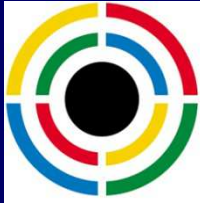

ISSF

**10TH
ISSF CHAMPIONSHIP ORGANIZERS WORKSHOP
MUNICH, GER**

23 NOV - 24 NOV 2012

Wind Flags for 50m Ranges and 300m Rifle Ranges

**Wind flag height must correspond with the central area of
the
bullets' flight paths**

**Athletes must check the wind flags before the
Preparation and
Sighting Time starts to be sure they do not obscure their
targets.**

**Only Range Officers or Jury Members may reposition
wind flags.**



**10TH
ISSF CHAMPIONSHIP ORGANIZERS WORKSHOP
MUNICH, GER
23 NOV - 24 NOV 2012**

Firing Point Equipment.

NO
chairs or stools for athletes may be placed on or near the
firing
points on Finals ranges;

Pre-Event Training (PET).
each athlete
must be allowed to train on his allocated competition
target for a
minimum of 40 minutes per relay (30 minutes per relay for
Rapid Fire Pistol) on the day before the event,



**10TH
ISSF CHAMPIONSHIP ORGANIZERS WORKSHOP
MUNICH, GER
23 NOV - 24 NOV 2012**

If an athlete has a gun or ammunition malfunction, he may repair it and continue shooting or, if the malfunction was **ALLOWABLE, continue shooting with another gun with the permission of the Jury and it has been approved by Equipment Control.**

No extra competition time is allowed to repair or replace a gun after any malfunction in 10 m, 50 m and 300 m Rifle or Pistol Elimination or Qualification Rounds.





**10TH
ISSF CHAMPIONSHIP ORGANIZERS WORKSHOP
MUNICH, GER
23 NOV - 24 NOV 2012**

Keys to improved Competitions

**This is a very important point and the way how it goes,
will be professional ONLY.**

**It means all OC must work on that to make their
Competition ; World Cup, etc. on a high level , this will
improve our sport**

**Of course we have to look forward, find new ideas , TV will
be one of the key point.**

**New ways to present our sport on the best way will be
also a key point.**



**10TH
ISSF CHAMPIONSHIP ORGANIZERS WORKSHOP
MUNICH, GER
23 NOV - 24 NOV 2012**

Keys to improved Competitions

To bring juniors in the game is a key point and as we can see now:

IOC approves new Shooting program for the 2014 Youth Olympic Games

IOC approves new Shooting program for the 2014 Youth Olympic Games

TWO NEW MIXED TEAM EVENTS WILL BE PART OF THE 2ND YOUTH OLYMPIC GAMES PROGRAM, WHILE THE TOTAL NUMBER OF QUOTAS WILL REMAIN UNCHANGED

All of us must start to find new ideas



ISSF

**10TH
ISSF CHAMPIONSHIP ORGANIZERS WORKSHOP
MUNICH, GER**

23 NOV – 24 NOV 2012



ISSF

International Shooting Sport Federation
Internationaler Schiess-Sportverband e.V.
Fédération Internationale de Tir Sportif
Federación Internacional de Tiro Deportivo

**Training Manual
Rifle
for ISSF Range Officials
& Judges**

Edition 2013 (First Draft, 10/2012)
Effective 1 January 2013

Edition 2013 (First Draft, 10/2012)
Copyright: ISSF

- 1 -



**10TH
ISSF CHAMPIONSHIP ORGANIZERS WORKSHOP
MUNICH, GER
23 NOV - 24 NOV 2012**

Manuals for Range Officer & Judges

Manuals Equipment Control

Manuals Announcements

etc.

In all documents you will find important details .

**You can find all updated documents from the ISSF HQ or ISSF web
side**

Conclusion

- Organizers, Technical Delegats, Jury members, all staff has to follow strictly ISSF Rules and Regulations.**
- Cooperation of all participants can be at the highest level and constant for the entire time of preparation and during the competition**
- The range officers and the Jury members must examine and control all the competitors during the training and competition period to prevent any discrepancy from the ISSF Rules.**
- The equipment control should be uniformed and thorough in all official ISSF Competitions**

- **Precisely because of that all staff, referees and equipment control officers and Jury members must pass practical training and preparation and especially regarding the new rules which are valid from 1. of January 2013.**
- **Special attention should be dedicated to the training to implementation of the new rules for the Finals in all events.**



**10TH
ISSF CHAMPIONSHIP ORGANIZERS WORKSHOP
MUNICH, GER
23 NOV - 24 NOV 2012**

**Thank you very much and all the best for the 2013
year**

